

ISS.	AMEND	DATE
1	ISSUED	10/10/14

PART NUMBER	PIN Ø
FC6814775	Ø2.50
FC6814785	Ø2.10

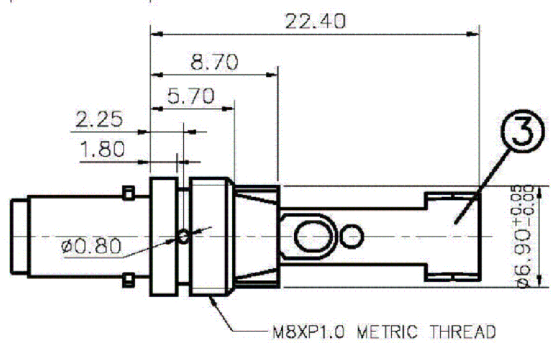
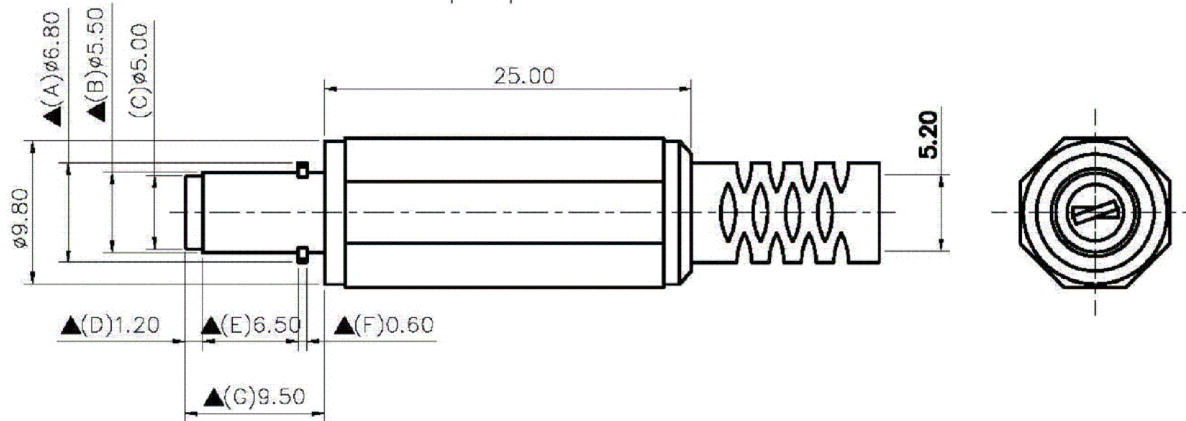
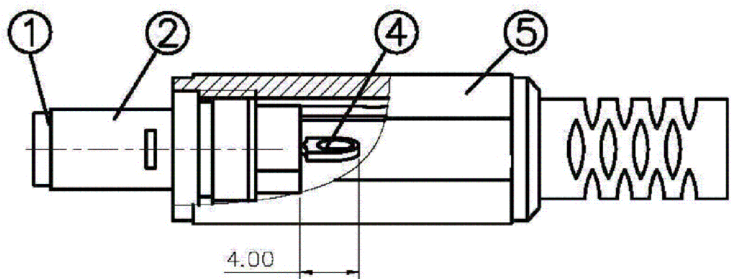
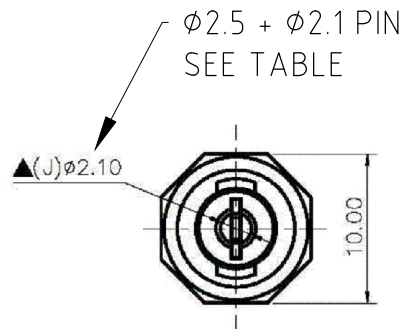

5.	Housing	PE	1	Black Color
4.	Terminal	0.6T Bronze	1	Nickel Plated
3.	Ground Terminal	0.4T Bronze	1	Nickel Plated
2.	Outer Sleeve	Brass	1	Nickel Plated
1.	Insulator Ring	POM	1	Black Color
NO.	Description	Material	Q'TY	Finish

SPECIFICATIONS

Contact Resistance : 30mΩ max
 Insulation Resistance : 100MΩ min at DC 500V
 Dielectric Withstanding Voltage : AC 500V for 1 minute

RoHS

COMPLIANT

TOLERANCE
 NO DEC. PLACE ±
 1 DEC. PLACE ±
 2 DEC. PLACE ±
 HOLE Ø ±
 ANGLES ±
 UNLESS OTHERWISE STATED

DO NOT SCALE